



# Thomas® XTSRLS71 Couplings Installation and Maintenance

Types XTSRLS71 & XTSRLS71-C • Sizes 726-4588

**Industrial Powertrain Solutions**  
**Regal Rexnord**

Application Engineering: 800 626 2093  
[PTSAAppEng@regalrexnord.com](mailto:PTSAAppEng@regalrexnord.com)  
[regalrexnord.com/REXNORD](http://regalrexnord.com/REXNORD)

**FORM**

**CP3-007E**  
**Revised**  
**August 2023**

**⚠ DANGER** Indicates a hazard which, if not avoided, will result in serious injury or death.

**⚠ WARNING** Indicates a hazard which, if not avoided, could result in serious injury or death.

**⚠ CAUTION** Indicates a hazard which, if not avoided, could result in minor or moderate personal injury.

**NOTICE** Indicates information considered important, but not hazard-related (e.g. messages relating to property damage).

## GENERAL SAFETY INSTRUCTIONS

### ⚠ WARNING

- Safety should be a primary concern in all aspects of coupling installation, operation, and maintenance.
- Proper lockout/tagout procedures must be followed to safeguard against unintentional starting of the equipment.
- Make sure to disengage the electrical power and any other sources of potential energy before you perform work on the coupling.
- Do not make contact with the coupling when it is rotating and/or in operation.
- Because of the possible danger to person(s) or property from accidents which may result from improper use or installation of these products, it is extremely important to follow the proper selection, installation, maintenance and operational procedures.
- Installation should be carried out by skilled personnel only. All personnel involved in the installation, service, operation, maintenance, and repair of this coupling and the connected equipment must read, understand, and comply with these Installation and Maintenance instructions. The Installation and Maintenance instructions and assembly drawing, if provided, must be at hand at the installation site.
- Packaging material can generate electrostatic charges. It may then become an explosive hazard. It must be removed from the coupling outside any hazardous areas.
- All rotating power transmission products are potentially dangerous and can cause serious injury. They must be properly guarded in compliance with OSHA, ANSI, ATEX, European machine safety standards and other local standards. It is the responsibility of the user to provide proper guarding.
- For this coupling to meet the ATEX requirements, you must precisely follow these installation and maintenance instructions, and the supplement form 0005-08-49-01. This supplement outlines the ATEX requirements. If the operator does not follow these instructions, the coupling will immediately be considered non-conforming to ATEX.

### ⚠ CAUTION

- The coupling should be stored in a dry corrosion protected environment, free from external loads (for example by stacking) to prevent damage which may cause a hazard when the coupling is put into service.
- For ATEX requirements the guard must have a minimum of 12.7 mm (1/2 in) radial clearance to the coupling outside diameter and allow for proper ventilation.
- For ATEX requirements the guard must have a minimum of 25.4 mm (1 inch) radial clearance to the coupling outside diameter and allow for proper ventilation when using the composite center tube coupling option.
- All conductive parts of the equipment should be connected in such a way that hazardous electrical potential differences cannot occur. In case insulated metal parts could be charged thus becoming a potential ignition source, earth connections must be provided.
- All work on the coupling must be performed when the coupling is at rest with no load.
- Do not start or jog the motor, engine, or drive system without securing the coupling components. If the equipment is started with only a hub attached, the hub must be properly mounted and ready for operation, with the key and set screw (if included) fastened. When the full coupling assembly is started, all fasteners and hardware must be completely and properly secured. Do not run the coupling with loose fasteners.
- Use explosive environment appropriate tools only, for more information see DIN EN 1127-1:2008:02, Annex A.
- The coupling may only be used in accordance with the technical data provided in the Thomas disc coupling catalog. Customer modifications

### NOTICE

- and alterations to the coupling are not permissible.
- All spare parts for service or replacement must originate from or be approved by Rexnord.

**Figure 1 – Thomas XTSRLS71 Coupling Range 726 to 4588 Sizes**

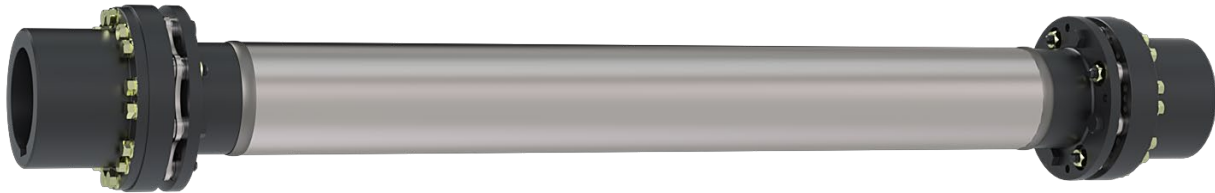

**Figure 2 – Thomas XTSRLS71-C Coupling Range 1088 to 2888 Sizes**



Handling considerations for the composite tube option:

The composite tube is very durable and will provide years of service if handled properly. Minor scuffs and surface abrasions on the spacer will not affect the performance of the coupling.

Soft spots caused by heavy impact, cuts or gouges are areas of concern. Any time a soft spot is seen; the coupling should be removed from service and the spacer replaced.

## 1. General Information

- 1.1 To ensure you have the most up-to-date version of this manual CP3-007, please visit [Rexnord.com](http://Rexnord.com) under resources > documentation.
- 1.2 Rexnord Thomas Couplings are designed to provide a mechanical connection between the rotating shafts of mechanical equipment, using a flexible disc to accommodate inherent misalignment while transmitting the power and torque between the connected shafts.
- 1.3 These instructions are intended to help you to install and maintain your Rexnord Thomas Coupling. Please read these instructions prior to installing the coupling, and prior to maintenance of the coupling

and connected equipment. Keep these instructions near the coupling installation and available for review by maintenance personnel. For special engineered couplings, Rexnord may provide an engineering drawing containing installation instructions that take precedence over this document.

- 1.4 Rexnord Industries, LLC owns the copyright of this material. These Installation and Maintenance instructions may not be reproduced in whole or in part for competitive purposes.

**Figure 2A – Thomas XTSRLS71-C Coupling Range 1088 to 2888 Sizes**

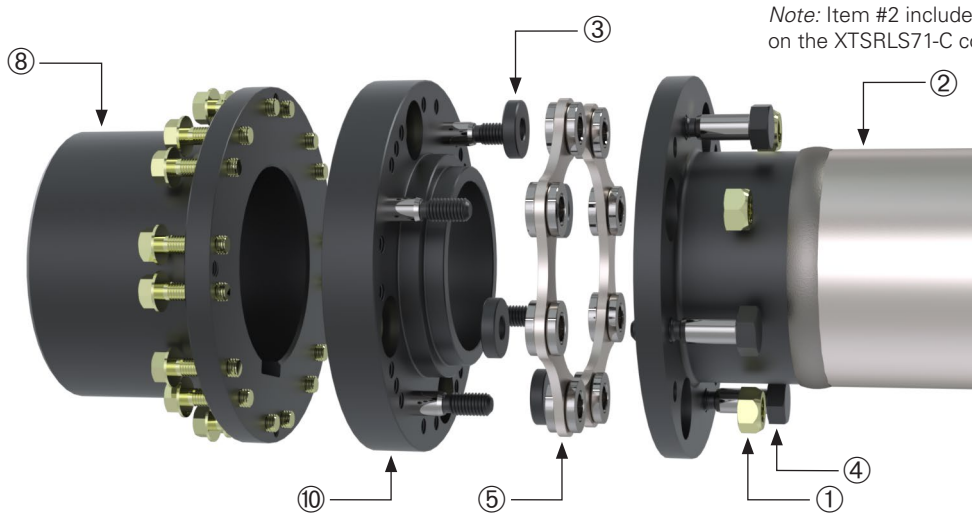

Note: Item #2 includes composite material on the XTSRLS71-C coupling.

**Table 1 – Rexnord Thomas XTSRLS71 Coupling Component Part Numbers**

Note: The circled numbers identified in the column headers below are the component numbers in **Figures 2A** (previous page) and **2B**.

XTSRLS71 Coupling Size	Standard Hub + Cap Screw Kit Part No.**	XL Hub + Cap Screw Kit Part No.	XXL Hub + Cap Screw Kit Part No.	Standard Adapter Part No. (2 per coupling)	XL Adapter Part No. (2 per coupling)	XXL Adapter Part No. (2 per coupling)	Center Spacer (1 per Coupling) ②			Disc Pack (2 per coupling)	Hardware Kit (Bolts, Locknuts, and Overload Bushings) for One Disc Pack ②			
							Part No.	"C" Length (in)	"C" Length (mm)		Parts Kit Part No.*	Bolts Quantity ②	Locknuts Quantity ①	Bushings Quantity ③
726	10001611	10001612	10001613	10001131	10001781	10002805	NO STANDARD LENGTHS DEFINED (LENGTH IS APPLICATION SPECIFIC)		10000091	10001561	6	6	6	
826	10001612	10001613	10001614	10001132	10001782	10002806			10000092	10001562	6	6	6	
996	10001613	10001614	10001615	10001133	10001783	10002807			10000093	10001563	6	6	6	
1088	10001614	10001615	10001616	10001134	10001784	10002808			10000094	10001564	8	8	8	
1298	10001615	10001616	10001617	10001135	10001785	10002809			10000095	10001565	8	8	8	
1548	10001616	10001617	10001618	10001136	10001786	10002810			10000096	10001566	8	8	8	
1698	10001617	10001618	10001619	10001137	10001787	10002811			10000097	10001567	8	8	8	
1928	10001618	10001619	10001620	10001138	10001788	10002812			10000098	10001568	8	8	8	
2068	10001619	10001620	10001621	10001139	10001789	10002813			10000099	10001569	8	8	8	
2278	10001620	10001621	10001622	10001140	10001790	10002814			10000100	10001570	8	8	8	
2468	10001621	10001622	10001623	10001141	10001791	10002815			10000101	10001571	8	8	8	
2698	10001622	10001623	10001624	10001142	10001792	10002816			10000102	10001572	8	8	8	
2888	10001623	10001624	10001631	10001143	10001793	10002817			10000103	10001573	8	8	8	
3058	10001624	10001631	10001625	10001144	10001794	10002818			10000104	10001574	8	8	8	
3358	10001631	10001625	10001626	10001145	10001795	10002819			10000105	10001575	8	8	8	
3668	10001625	10001626	10001627	10001146	10001796	10002820			10000106	10001576	8	8	8	
3908	10001626	10001627	10001628	10001147	10001797	10002821			10000107	10001577	8	8	8	
4178	10001627	10001628	10001629	10001148	10001798	10002822			10000108	10001578	8	8	8	
4588	10001628	10001629	10001630	10001149	10001799	10002823			10000109	10001579	8	8	8	

\* Disc pack hardware sold as kits only.

\*\* All hub part numbers are non bored and include adapter hub hardware kit.

**Figure 2B – Rexnord Thomas XTSRLS71 Coupling Components**

\*\*Adapter hub capscrews are included with the standard, XL or XXL hub.



Thomas XTSRLS71 & XTSRLS71-C Couplings are delivered from the factory with a fully assembled center member consisting of a center spacer, two adapters, disc packs, bolts, washers and locknuts that have already been tightened at the factory to the torque specified in **Table 5**. The center member assembly is ready for field installation and it is recommended that you do not disassemble it unless you are replacing the disc packs. Cap screws will need to be installed and tightened during installation.

## 2. Hub Mounting

**DANGER!** Be sure to disengage the electrical power and any other sources of potential energy before you perform work on the hub and coupling assembly.

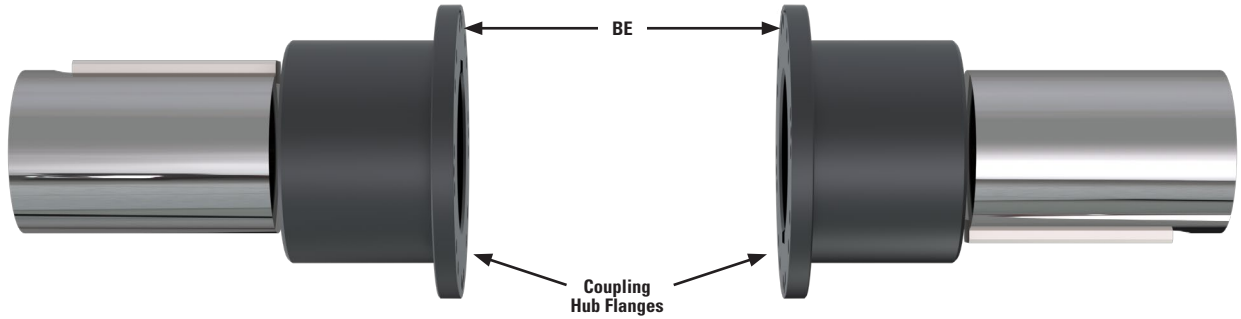

**Figure 3 – Mounting Hubs on Shafts**

- 2.1 Examine the coupling assembly to assure there is no visible damage.
- 2.2 Clean the hub bores and shafts using lint free cloth. Remove any nicks or burrs.
- 2.3 The key(s) should have a close side-to-side fit in the keyway in the hub and shaft, with a slight clearance over the top when assembled
- 2.4 Remove the cap screws that attach the hubs to the adapters, and remove both hubs.

**DANGER!** Touching hot hubs causes burns. Wear safety gloves to avoid contact with hot surfaces.

**CAUTION!** When heating hubs is required, an oven is preferred and an open flame is not recommended. If flame heating is considered mandatory, it is important to provide uniform heating to avoid distortion and excessive temperature. A thermal stick applied to the hub surface will help determine the hub temperature.

## 3. Straight Bore with Clearance/Slip Fit

**NOTICE:** When using the XTSRLS71 & XTSRLS71-C for vertical applications the usage of the hub to shaft interface must be interference fit.

- 3.1 Install the key(s) in the shaft.
- 3.2 Check to be sure that the set screw(s) in the hub does not protrude into the keyway or the bore. Remove or back out the set screw to provide clearance during assembly.
- 3.3 Slide the hub up the shaft to the desired axial position.
- 3.4 If used; assemble and tighten the set screw(s) using a calibrated torque wrench to the values shown in **Table 2**.

**Table 2 – Set Screw Tightening Torque**

Set Screw Size		#6-40	#8-32 NF	#10-32 NF	1/4-28 NF	5/16-24 NF	3/8-24 NF	1/2-20 NF	5/8-11 NC	3/4-10 NC	7/8-9 NC	1.00-8 NC
Hex Head Key Size		1/16	5/64	3/32	1/8	5/32	3/16	1/4	5/16	3/8	1/2	9/16
Tightening Torque	(Nm)	1	2	4	9	16	31	75	120	217	325	452
	(lb-in)	9	17	31	76	144	276	660	1,060	1,920	2,880	4,000

Set Screw Size		M3	M4	M5	M6	M8	M10	M12	M16	M20	M24
Hex Head Key Size		1.5	2	4	3	4	5	6	8	10	12
Tightening Torque	(Nm)	0.8	2	3	6	12	25	50	100	206	379
	(lb-in)	7	17	30	55	110	220	440	880	1,827	3,358

**CAUTION!** Never use two set screws with one on top of the other in the same tapped hole.

## 4. Straight Bore with Interference Fit

- 4.1 Accurately measure the bore and shaft diameters to assure proper fit.
- 4.2 Install the key(s) in the shaft.
- 4.3 Heat the hub in an oven until the bore is sufficiently larger than the shaft.

- 4.4 275°F (135°C) is usually sufficient for carbon steel hubs. Do not exceed 400°F (205°C).
- 4.5 With the hub expanded, install it quickly on the shaft to the desired axial position. A pre-set axial stop device can be helpful.

**Figure 4 – Shaft end to hub face measurement example.**

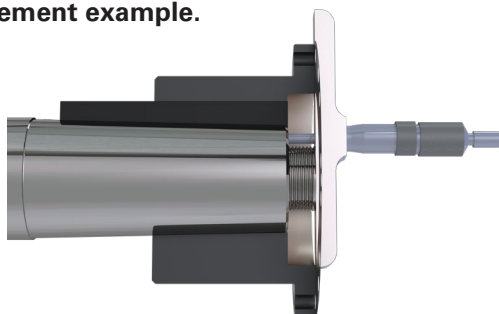

**Figure 5 – Dial indicator placement for axial draw measurement example.**

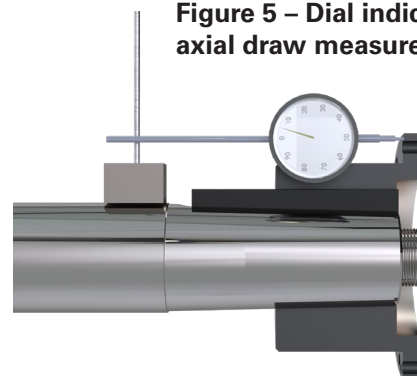

## 5. Taper Bore

- 5.1 Check for acceptable contact pattern between the hub and the shaft.
- 5.2 Put the hub on the shaft, keeping the keyways (if existing) aligned.
- 5.3 Lightly tap the face of the hub with a soft mallet. The resultant position will provide a starting point for the hub axial draw up.
- 5.4 Use a depth micrometer to measure the distance from the shaft end to the hub face, as shown in **Figure 4**. Record the dimension.
- 5.5 Mount a dial indicator to read axial hub advancement, as shown in **Figure 5**. Alternatively, the indicator can be positioned to contact the end of the hub. Set the indicator to “zero”.
- 5.6 Remove the hub and install the key(s) in the shaft.
- 5.7 Heat the hub in an oven until the bore is sufficiently larger than the shaft.
- 5.8 350°F (177°C) is usually sufficient for carbon steel hubs. Do not exceed 500°F (260°C).
- 5.9 Higher temperatures may be required for higher interference fit levels where alloy steel hubs may be encountered. A general rule to consider is that for every 160°F increase in temperature, steel will expand 0.001 inch for every inch of shaft diameter (or 0.029 mm/100°C). When calculating temperatures, also consider additional expansion to provide clearance and allow for a loss of heat and subsequent shrinkage during the handling process.
- 5.10 With the hub expanded, install it quickly on the shaft to the “zero” set point. Continue to advance the hub up the taper to the desired axial position, as defined by Rexnord’s customer. Use the indicator as a guide only. A pre-set axial stop device can be helpful.
- 5.11 Inspect the assembly to verify that the hub is properly positioned. Consult Rexnord if necessary.
- 5.12 Install any hub axial retention device (if any) in accordance with the equipment manufacturer’s specifications.

**Figure 6 – Angular Misalignment**

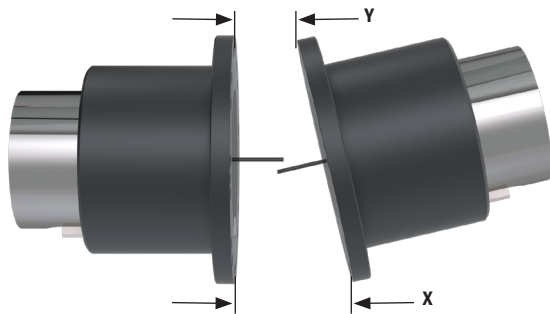

## 6. Shaft Alignment

**NOTICE:** Soft Foot — The equipment must rest flat on its base. If one or more feet of the machine are shorter, longer, or angled in some way to prevent uniform contact (a condition commonly known as “soft foot”) it must now be corrected.

**NOTICE:** To improve the life of the coupling, the shafts must be aligned to minimize distortion of the flexing elements. Shaft alignment is required in the axial, parallel, and angular directions, with each of these values not to exceed the recommended ratings for the coupling and the alignment values shown in **Table 3**. Shaft alignment can be measured using various established methods, including Laser Alignment, Reverse Dial Indicator, and Rim and Face.

- 6.1 Move the connected equipment to achieve acceptable alignment. When well aligned, the disc packs will be centered and approximately parallel to their mating flange faces and the flexing elements will have little visible waviness when viewed from the side.
- WARNING!** As a guide, the maximum and minimum values for dimension “N” shown in **Figure 8** are given in **Table 3**. These dimensions are suggested for initial installation. Additional capacity is available to compensate for thermal and structural equipment movement. Maximum axial capacity values for these couplings are also given in **Table 3**.
- 6.2 **Table 3** shows installation limits for Angular and Parallel alignment. The “Angular Alignment Total Indicator Reading” value is the maximum difference between the measurements (X-Y) taken at opposite ends of the hub flange, as shown in **Figure 6**. The “Parallel Alignment” value (P) is the offset between the centers of the hubs, as shown in **Figure 7**. If parallel offset is measured by rotating the hubs with a dial indicator on the outside diameter, the total indicated reading should be divided by (2) to calculate P.
  - 6.3 The “Angular Misalignment” value is the maximum difference between the measurements X and Y taken at opposite ends of the hub flanges, as shown in **Figure 6**.
  - 6.4 The “Parallel Misalignment” value (P) is the offset between the centers of the hubs, as shown in **Figure 7**.

**Figure 7 – Parallel Misalignment**

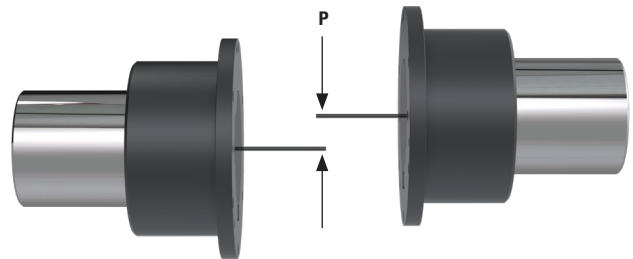

**Figure 8**

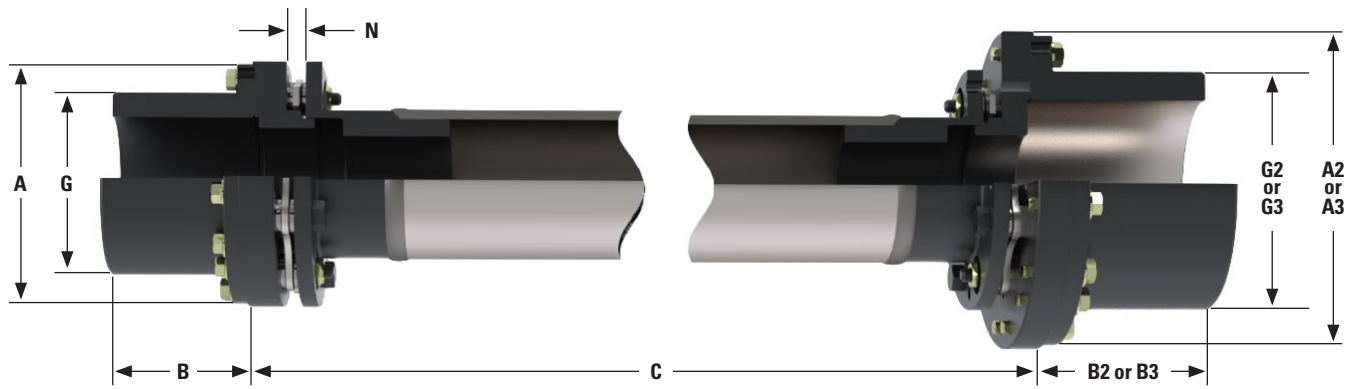

**Table 3 – Alignment Values**

Size	"A" Dimension		"A2" Dimension		"A3" Dimension		"N" Dimension				Installation Axial Limits +/-		Axial Capacity +/-		Recommended Installation Limits***							
	Std. Hub		XL Hub		XXL Hub		Min.	Max.	Min.	Max.					Parallel Misalignment				Angular Misalignment Between Hubs Installation (X-Y) Standard Hub		Angular Misalignment Between Hubs Installation (X-Y) XL Hub	
	Parallel Alignment Total Indicator Reading (TIR*)		Installation Limit Parallel Offset "P"***																			
	(in)	(mm)	(in)	(mm)	(in)	(mm)	(in)	(in)	(mm)	(mm)	(in)	(mm)	(in)	(mm)	(in)	(mm)	(in)	(mm)	(in)	(mm)		
726	3.74	95.0	4.25	108.0	5.08	129.0	0.33	0.35	8.3	8.8	0.026	0.65	0.051	1.3	0.008 inch per inch (0.008 mm per mm) of 'C' dimension	0.004 inch per inch (0.004 mm per mm) of 'C' dimension	0.005	0.13	0.006	0.15		
826	4.25	108.0	5.08	129.0	5.51	140.0	0.36	0.38	9.1	9.6	0.030	0.75	0.059	1.5			0.006	0.15	0.007	0.18		
996	5.08	129.0	5.51	140.0	6.54	166.0	0.37	0.39	9.3	9.9	0.035	0.90	0.070	1.8			0.007	0.18	0.008	0.20		
1088	5.51	140.0	6.54	166.0	7.83	199.0	0.40	0.42	10.1	10.7	0.025	0.65	0.051	1.3	0.004 inch per inch (0.004 mm per mm) of 'C' dimension	0.002 inch per inch (0.002 mm per mm) of 'C' dimension	0.005	0.13	0.006	0.15		
1298	6.54	166.0	7.83	199.0	8.66	220.0	0.50	0.52	12.6	13.3	0.031	0.80	0.061	1.6			0.006	0.15	0.008	0.20		
1548	7.83	199.0	8.66	220.0	9.66	245.4	0.57	0.59	14.4	15.1	0.037	0.90	0.073	1.8			0.008	0.20	0.008	0.20		
1698	8.66	220.0	9.66	245.4	10.39	264.0	0.61	0.64	15.4	16.2	0.040	1.00	0.080	2.0			0.008	0.20	0.009	0.23		
1928	9.66	245.4	10.39	264.0	11.44	291.0	0.66	0.69	16.7	17.4	0.046	1.15	0.091	2.3			0.009	0.23	0.10	0.25		
2068	10.39	264.0	11.44	291.0	12.32	313.0	0.71	0.74	18.0	18.8	0.049	1.25	0.097	2.5			0.010	0.25	0.11	0.28		
2278	11.44	291.0	12.32	313.0	13.58	345.0	0.74	0.77	18.8	19.5	0.054	1.35	0.107	2.7			0.011	0.28	0.012	0.30		
2468	12.32	313.0	13.58	345.0	15.00	381.0	0.79	0.82	20.1	20.8	0.058	1.50	0.116	3.0			0.012	0.30	0.013	0.33		
2698	13.58	345.0	15.00	381.0	15.94	405.0	0.91	0.94	23.0	23.9	0.064	1.60	0.127	3.2			0.013	0.33	0.014	0.36		
2888	15.00	381.0	15.94	405.0	17.20	437.0	0.97	1.00	24.7	25.4	0.068	1.75	0.136	3.5			0.014	0.36	0.015	0.38		
3058	15.94	405.0	17.20	437.0	18.98	482.0	0.97	1.01	24.7	25.6	0.072	1.85	0.144	3.7	0.015	0.38	0.017	0.43				
3358	17.20	437.0	18.98	482.0	19.80	503.0	1.06	1.09	27.0	27.7	0.079	2.00	0.158	4.0	0.017	0.43	0.018	0.46				
3668	18.98	482.0	19.80	503.0	20.83	529.0	1.18	1.21	29.9	30.8	0.087	2.20	0.173	4.4	0.018	0.46	0.019	0.48				
3908	19.80	503.0	20.83	529.0	23.94	608.0	1.25	1.30	29.9	30.8	0.093	2.35	0.185	4.7	0.019	0.48	0.020	0.51				
4178	20.83	529.0	23.94	608.0	25.51	648.0	1.40	1.43	31.9	33.0	0.099	2.50	0.197	5.0	0.020	0.51	0.023	0.58				
4588	23.94	608.0	25.51	648.0	26.69	678.0	1.48	1.52	35.5	36.4	0.108	2.75	0.216	5.5	0.023	0.58	0.024	0.61				

\* Parallel misalignment measured by rotating the hubs with a dial indicator on the outside hub diameter will result in a maximum Total-Indicated-Reading.

\*\* Parallel offset "P" is equivalent to one-half of the TIR measurement using dial indicators.

\*\*\* During installation and/or operation, do not exceed the maximum misalignment capacity of coupling.

For sizes 726-996 maximum misalignment capacity of coupling is 1/2° per disc pack.

For sizes 1088-4588 maximum misalignment capacity of coupling is 1/3° per disc pack.

Refer to Bulletin 538-214 "Coupling Alignment Fundamentals" for more details regarding alignment methods and procedures.

## 7. Final Assembly

*Note:* XTSRLS71 & XTSRLS71-C couplings are delivered from the factory with a fully assembled center member subassembly with locknuts tightened at the factory to the torque specified in **Table 5**. The center member subassembly is ready for field installation, and we recommend that you do not disassemble it (unless you are replacing the disc packs).

- 7.1 Verify that the hubs have been mounted to provide the correct “C” dimension shown in **Figure 8** and defined in **Table 1**.

*Note:* The “C” dimension is the distance measured between the faces of the two hub flanges. Note that the “C” dimension does not include the narrow extended length of material that provides the pilot on the outside diameter of the hub.

**Table 4 – Compression Cap Screws**

Coupling Size	Compression Cap Screws	
	Flanged Hex Head Style	
	Capscrew Size	Quantity
726	M6 x 20 mm [0.787 inch]	6
826	M6 x 20 mm [0.787 inch]	6
996	M8 x 25 mm [0.984 inch]	6
1088	M6 x 25 mm [0.984 inch]	16
1298	M8 x 30 mm [1.181 inch]	16
1548	M10 x 35 mm [1.378 inch]	16
1698	M10 x 40 mm [1.575 inch]	16
1928	M12 x 40 mm [1.575 inch]	16
2068	M12 x 40 mm [1.575 inch]	16
2278	M12 x 50 mm [1.968 inch]	16
2468	M14 x 50 mm [1.968 inch]	16
2698	M12 x 60 mm [2.362 inch]	24
2888	M14 x 70 mm [2.756 inch]	24
3058	M16 x 70 mm [2.756 inch]	24
3358	M16 x 70 mm [2.756 inch]	24
3668	M16 X 80 mm [3.149 inch]	32
3908	M16 X 80 mm [3.149 inch]	32
4178	M16 X 80 mm [3.149 inch]	32
4588	M20 x 90 mm [3.543 inch]	32

**CAUTION!** Tighten the compression cap screws equally to compress both ends only enough to allow the center member subassembly to fit between the hubs. (Do not tighten more than necessary to provide clearance for assembly.)

- 7.5 Remove the center member compression cap screws, allowing the hub pilots to make contact with the outside diameter of the adapter.

*Note:* As a guide, measure the distance between flanges known as dimension “N” shown in **Figure 7** and given in **Table 4**.

*Note:* If your coupling utilizes a short center member with scalloped flanges (clearance hole area removed) follow these supplemental instructions to aid in assembly.

- 7.6 Lubricate the cap screw threads and insert the cap screws through the hub flange clearance holes and into the mating threaded holes in the adapter.

- 7.2 Due to the hub-to-adapter piloting feature, the center member subassembly must be compressed to allow it to be slipped between the two end hubs.

*Note:* Use the compression cap screws (provided) as defined in **Table 4** to compress the center member assembly by inserting them through the holes in the flanges of the center spacer and threading them into the adapter tapped holes as shown in **Figure 9**.

- 7.3 Make sure that the adapter and the hub flange face and pilots are free from foreign material, nicks and burrs to allow for proper pilot seating.

- 7.4 Place the compressed center member between the coupling hubs, lining up the tapped holes in the adapter with the cap screw clearance holes in the hub. If the coupling was assembly balanced, also align any match marks.

**Figure 9**

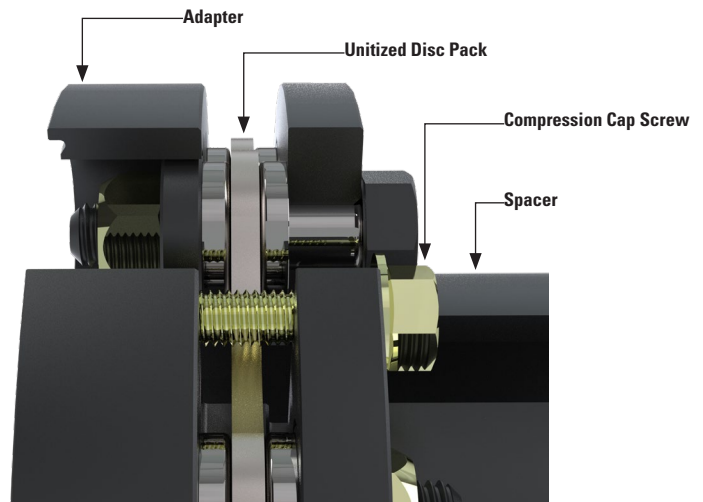

- 7.7 Tighten each cap screw to the torque as listed in **Table 5**
- 7.8 Start bolt through bolt hole in spacer flange until body of bolt is in contact with disc pack washer. The threaded portion of the bolt is not exposed on other end of disc pack.

For further help with the installation or alignment consult Regal Rexnord.

**Table 5 – Cap Screw Tightening Torques**

Coupling Size	"A" Dimension Std. Hub		Flange Hex Head Cap Screw-Standard Hub				"A2" Dimension XL Hub		Flange Hex Head Cap Screw-XL Hub			
			Bolt Size	Torque		Wrench Size (mm)			Bolt Size	Torque		Wrench Size (mm)
	(in)	(mm)		(mm)	(ft-lb)		(Nm)	(in)		(mm)	(mm)	
726	3.74	95.0	M6x20	12.3	16.7	10	4.25	108.0	M6x20	12.3	16.7	10
826	4.25	108.0	M6x20	12.3	16.7	10	5.08	129.0	M8x25	27	36	13
996	5.08	129.0	M8x25	27	36	13	5.51	140.0	M6x25	12	16.7	10
1088	5.51	140.0	M6x25	12.3	16.7	10	6.54	166.0	M8x30	27	36	13
1298	6.54	166.0	M8x30	27	36	13	7.83	199.0	M10x35	51	69	15
1548	7.83	199.0	M10x35	51	69	15	8.66	220.0	M10x40	51	69	15
1698	8.66	220.0	M10x40	51	69	15	9.66	245.4	M12x40	92	124	16
1928	9.66	245.4	M12x40	92	124	16	10.39	264.0	M12x40	92	124	16
2068	10.39	264.0	M12x40	92	124	16	11.44	290.5	M12x50	92	124	16
2278	11.44	290.5	M12x50	92	124	16	12.32	313.0	M14x50	142	193	18
2468	12.32	313.0	M14x50	142	193	18	13.58	345.0	M12x60	92.0	124	16
2698	13.58	345.0	M12x60	92	124	16	15.00	381.0	M14x70	142	193	18
2888	15.00	381.0	M14x70	142	193	18	15.94	405.0	M14x70	142	193	18
3058	15.94	405.0	M14x70	142	193	18	18.98	482.0	M16x70	218	295	21
3358	17.20	437.0	M16x70	218	295	21	18.98	482.0	M16x80	218	295	21
3668	18.98	482.0	M16x80	218	295	21	19.80	503.0	M16x80	218	295	21
3908	19.80	503.0	M16x80	218	295	21	20.83	529.0	M16x80	218	295	21
4178	20.83	529.0	M16x80	218	295	21	23.94	608.0	M20x90	427	579	27
4588	23.94	608.0	M20x90	427	579	27	25.51	648.0	M20x100	427	579	27

Note: These torque values are approximate for Cap screws with lubricated threads.

**8. Disc Pack Replacement**

If it becomes necessary to replace the disc packs, it can be done as follows:

**NOTICE:** The XTSRLS71 & XTSRLS71-C center member subassemblies have their locknuts factory tightened.

- 8.1 Remove the center member subassembly by removing all cap screws, compressing the center member subassembly (using the cap screws as defined in the final assembly procedure) and dropping it out from between the hubs.
- 8.2 There are jacking screw tapped holes in each end hub to disengage the pilots between the hubs and adapters, using the compression cap screws (provided) as defined in **Table 4**.
- 8.3 Remove all locknuts, bolts, washers, and disc packs. Special wrenches may be required.
- 8.4 Clean the two adapters and the center spacer, removing any nicks and burrs. See **Figure 3**.
- 8.5 Install the new disc packs to the adapters first.  
**NOTICE:** Match marks (if applied at assembly balance) must be in-line to maintain balance integrity.
- 8.6 Install the disc packs to the adapter first so that the bushing heads in the disc pack line up with the bolt holes in the adapter flanges as shown in **Figure 10A**.
- 8.7 Insert the bolts through the adapter bolt holes and disc pack assembly.

The last bolt will upon tightening will apply the pre-stretch on the flex element without the need to use a mallet to force the bolt through the disc pack due to the lead chamfer on the bolt body.

- 8.8 Align a clearance hole of the spacer over the bolt install an overload bushing as shown above.
- 8.9 Make sure all of the parts pilot on the body ground area on the bolt.
- 8.10 Apply a clean motor oil to the bolt threads and install a locknut on each bolt, but do not tighten the locknuts, yet.  
**NOTICE:** All bolt threads must be lubricated prior to assembly. A clean motor oil is recommended. Do not use lubricants containing molybdenum disulfide or greases. Use **Figure 10B** for the opposing end assembly detail.
- 8.11 Install the disc packs to the spacer first so that the bushing heads in the disc pack line up with the bolt holes in the spacer flanges as shown in **Figure 10B**.
- 8.12 Insert the bolts through the spacer bolt holes and disc pack assembly.  
**NOTICE:** The last bolt will upon tightening will apply the pre-stretch on the flex element without the need to use a mallet to force the bolt through the disc pack due to the lead chamfer on the bolt body.
- 8.13 Align a clearance hole of the adapter over the bolt. Install an overload bushing onto each bolt as shown above.
- 8.14 Make sure all of the parts pilot on the body ground area on the bolt.
- 8.15 Apply a clean motor oil to the bolt threads and install a locknut on each bolt, but do not tighten the locknuts, yet.  
**NOTICE:** All bolt threads must be lubricated prior to assembly. A clean motor oil is recommended. Do not use lubricants containing molybdenum disulfide or greases.

**Figure 10A**

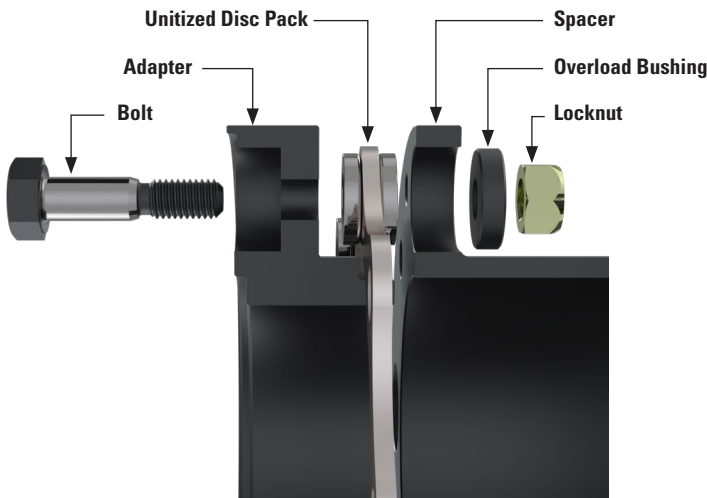

**Figure 10B**

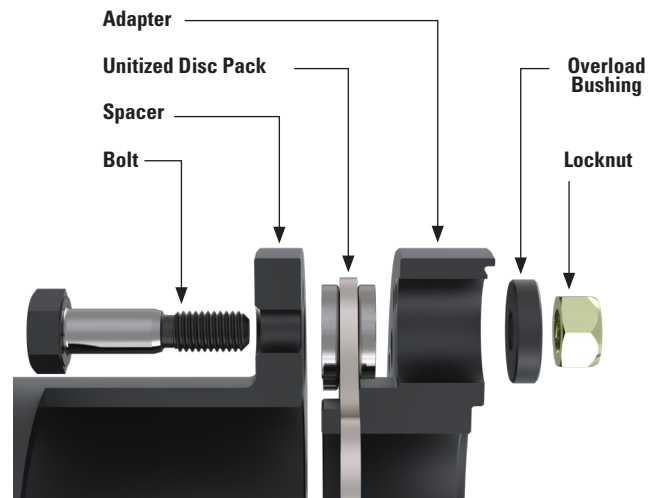

**Figure 11 —  
6 Bolt Pattern  
726, 826 and  
996 sizes**



**Figure 12 —  
8 Bolt Pattern  
1088 and  
larger sizes**

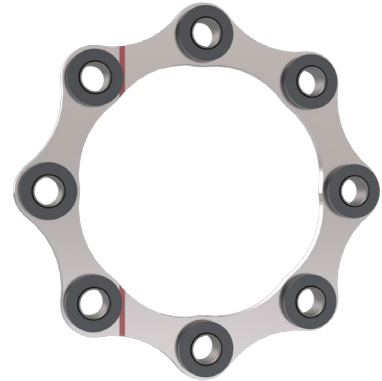

8.16 Slightly tighten all locknuts using an alternating progressive pattern making sure the disc pack is not distorted and all the bolts are fully seated.

8.17 Now tighten each locknut to the appropriate torque value shown in **Table 6**, using an incremental torque in a progressive pattern.

8.18 Proceed to install the center member subassembly as outlined in the Final Assembly section.

**NOTICE:** When possible, it is recommended that all locknuts have their tightening torque checked after several hours of initial operation.

For spare replacement parts, see **Table 1**.

**Table 6 – Lock Nut Tightening Torque**

Coupling Size	"A" Dimension Std. Hub		Bolt Size (mm)	Locknut Torque		Wrench Size (mm)
	(in)	(mm)		(ft-lb)	(Nm)	
726	3.74	95.0	M5	4.7	6.4	8
826	4.25	108.0	M6	8.1	11	11
996	5.08	129.0	M8	18	24	14
1088	5.51	140.0	M8	19	26	15
1298	6.54	166.0	M10	39	53	18
1548	7.83	199.0	M12	66	90	21
1698	8.66	220.0	M14	110	150	22
1928	9.66	245.4	M16	162	220	24
2068	10.39	264.0	M18	236	320	27
2278	11.44	290.5	M20	266	360	30
2468	12.32	313.0	M22	384	520	32
2698	13.58	345.0	M24	575	780	36
2888	15.00	381.0	M27	885	1200	41
3058	15.94	405.0	M27	885	1200	41
3358	17.20	437.0	M30	1200	1600	46
3668	18.98	482.0	M33	1500	2000	50
3908	19.80	503.0	M33	1500	2000	50
4178	20.83	529.0	M36	2100	2800	55
4588	23.94	608.0	M42	3200	4400	65

*Note:*

1. These torque values are approximate for steel bolts with lubricated threads.
2. Bolts should be held from rotating while the locknuts are tightened to the values shown. Do not tighten the fastener by rotating the bolt head.