

# Rexnord Falk Wrapflex Elastomer Coupling



## CUSTOMER-FOCUSED SOLUTIONS. RELIABLE PERFORMANCE. TRUSTED BRANDS.

You want a trusted name when it comes to providing engineered power transmission products that improve productivity and efficiency. Rexnord® provides superior products for your industrial applications world wide. We work closely with you to reduce maintenance costs, eliminate redundant inventories and prevent equipment downtime.

### FALK WRAPFLEX®

Low cost elastomer in shear with replace-in-place element. Easy installation and service without need to move hubs or connected equipment.

Falk® is a Rexnord brand.

### Design Features include:

- Replace-in-place design allows quick & easy element replacement without having to move the hubs
- High capacity ratings at a very competitive price
- Polyurethane element has excellent wear and chemical resistance with high temperature insert options that can operate up to 250°F

### Applications:

- Pumps
- Compressors
- General Purpose Machinery

### Industry Compliant:

- ATEX II 2GD c T5



ATEX II 2GD c T5





Torque Demands Driven Machine	Typical Application for Electric Motor or Turbine Driven Equipment	Typical Service Factor
	Constant torque such as centrifugal pumps, blowers and compressors	1.0
	Continuous duty with some torque variations including plastic extruders and forced draft fans	1.5
	Light shock loads from metal extruders, cooling towers and log haulers	2.0
	Moderate shock loading as expected from a car dumper, stone crusher, vibrating screen	2.5
	Heavy shock load with some negative torques from reciprocating pumps, compressors, reversing turnout tables	3.0
	Frequent torque reversals such as reciprocating compressors with frequent torque reversals which do not necessarily include reverse rotations	Consult Rexnord Engineering

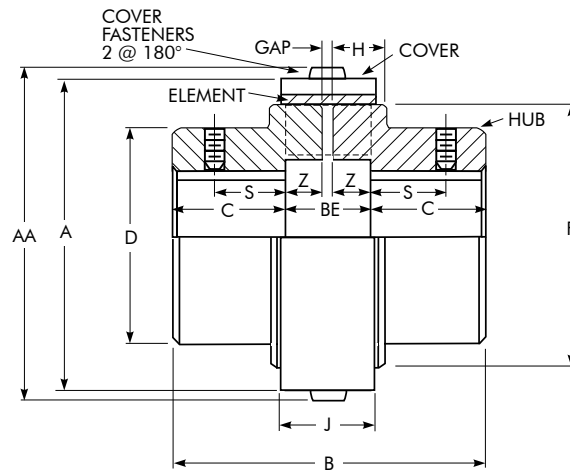

Dimensions (mm)

Cplg Size ①	Torque Rating (Nm)	Allow Speed RPM	Min Bore	Max Bore ②	A		AA		B	BE ⑤	C	D	F	H	J	S	Z	GAP ⑤	Cplg Wt (kg) ③	
					Nylon Cover	Steel Cover ④	Nylon Cover	Steel Cover ④											Nylon Cover	Steel Cover ④
5R	62	4500	12,7	38,00	76,5	76,5	80,5	80,4	71,9	19,8	25,9	59,9	64,0	15,0	23,1	16	8,9	2,00	1,35	1,49
10R	130	4500	15,88	48,00	90,4	90,4	94,5	94,4	91,9	23,9	34,0	72,1	75,9	19,1	27,9	22,4	10,9	2,00	2,49	2,72
20R	316	4500	19,05	60,00	126	124	132	130	121,9	32,0	45,0	91,9	102,1	24,9	37,1	25,4	15,0	2,00	5,64	6,09
30R	520	4500	25,4	65,00	146,6	143	153	149	151,9	36,1	57,9	104,9	118,1	29	41,9	31,8	17,0	2,00	9,41	10
40R	1028	3600	28,58	85,00	182,1	177	190	185	181,1	47,0	67,1	130	150,1	34	54,6	41,4	21,1	5,00	17,1	18,1
50R	2508	3000	31,75	105,00	230,9	224	239	232	214,9	60,7	77,0	178,1	190	46	69,6	44,5	27,9	5,00	35,8	37,7
60R	4011	2500	50,8	135,00	-	267	-	278	275,3	75,4	100,1	209,6	228,1	60,2	67,1	-	35,3	5,00	-	66,4
70R	8011	2100	69,85	160,00	-	310	-	321	324,1	84,1	119,9	251	270	69,6	74,9	-	39,6	5,00	-	111
80R	15027	1800	85,73	190,00	-	370	-	381	376,9	97,0	140	270	327,9	83,3	85,1	-	45,5	6,00	-	166

- ① Wrapflex is a metric product. Metric to inch conversions may not be direct. Dimensions are for reference only and are subject to change without notice unless certified.
  - ② AGMA Class 1 clearance fit bores are standard for Sizes 5R thru 50R, with two setscrews (one over keyway and one at 90°). Interference fit bores and one setscrew over keyway is standard for 60 thru 80R. Long hubs and interference fits are available and recommended when at or near maximum bore and: a) Number of start/stop cycles exceeds 10 per hour; or b) Application service factor = 2.0 or higher.
  - ③ Coupling assembly weight is based on "no bore" hubs. For coupling assembly weight and bored hubs, subtract the following value for each hub: (5,08)(Bore)2(C) kg Bore in "millimeters".
  - ④ Nylon cover is standard on Sizes 5R thru 50R, with an epoxy-coated steel cover as an option. Epoxy-coated steel cover is standard on Sizes 60R thru 80R, with no option for nylon cover.
  - ⑤ "BE" = Standard "Distance Between Shaft Ends" with hubs mounted flush to the shaft ends. "GAP" = Minimum allowable "Distance Between Shaft Ends". Any shaft end spacing between the "GAP" and "BE" dimensions is acceptable. However, if utilizing a shaft end spacing less than the "BE" dimension, the key should not extend beyond the hub face in order to prevent potential interference with the flex element.
- \* Rough bore hubs shown, see bulletin [491-110M](#) for QD and Taper-lock BSW hub options.